

ECS3
ELECTRIC CYLINDERS
HEAVY DUTY
SERIES 10

ISO 15552

DESCRIPTION

- A - Rod guide
- B - Rod
- C - Piston
- D - Nut
- E - Bearing
- F - Coupling
- G - Coupling carter
- H - Screw
- L - Magnetic ring
- M - Barrel
- N - Front cap

- Electric cylinders made with mounting interfaces in compliance with ISO 15552.
- The linear movement transmission is realized by means of precise and with high efficiency ball screws. In particular, this series is characterized by a selection of oversized ball screws. This feature maximizes the life of the cylinders and makes them suitable for the most demanding applications.
- The cylinder design is made to minimize vibrations: the piston is precisely guided in the barrel with double zero-backlash sliding guide; the shaft end of the screw is supported by a bearing; the rod is guided into the front head with a long linear bushing.
- The cylinder can be equipped with a robust integrated anti-rotation device.
- The piston is equipped with a magnetic ring and the barrel is equipped with external slots to accommodate any sensors. The rod has an increased external diameter and thickness to maximize rigidity and resistance to radial and buckling loads. The screw is supported by high capacity bearings to allow the transmission of high loads in both directions
- A high-strength timing belt is used to connect the motor in parallel, in order to have reliability and strength of the torque transmission chain.
- Many pneumatic accessories can be used to fix and mount the electric cylinder, including intermediate trunnions

PERFORMANCES

Size		32	40	50	63	80	100	125
Maximum axial force	N	2100	3400	6400	11100	20900	53500	123400
Maximum speed	mm/s	1333	1333	1333	1333	833	533	423
Maximum acceleration	m/s ²	8	10	13	16	13	13	13
Standard stroke up to	mm	800	1200	1400	1600	2000	2600	3300
Maximum average axial force for 2500 km life	N	1375	1700	2000	3635	4500	19745	49640
Ambient temperature range	°C	-20 / +100						
Max air humidity allowed for IP65 (without condensation)	%	90						
Protection degree		IP44 or IP65						



1 - IDENTIFICATION CODE

ECS3	-		/		-	B	/	10	-		/		-		/	M
-------------	---	--	---	--	---	----------	---	-----------	---	--	---	--	---	--	---	----------

Size: _____

32 = ISO 32
40 = ISO 40
50 = ISO 50
63 = ISO 63
80 = ISO 80
100 = ISO 100
125 = ISO 125

Mounting type: _____

T = front threaded holes (standard)
A = front flange (MF1)
B = rear flange (MF2)
N = double flange (MF1+MF2)
C = rear clevis (MP2)
D = rear eye (MP4)
G = feet (MS1)
L = intermediate trunnions (MT4)

Rod end: _____

M = male thread (standard)
F = female thread
C = clevis cap
S = spherical cap
L = self-centring coupler cap
X = special

Stroke: _____

max 800 mm for size 32
max 1200 mm for size 40
max 1400 mm for size 50
max 1600 mm for size 63
max 2000 mm for size 80
max 2600 mm for size 100
max 3300 mm for size 125
For longer strokes contact our technical office.

Screw type: _____

B = ball screw
R = roller screw (upon request)

Screw lead: _____
(see overall dimension tables of each size for availability and matches)

04 = 4 mm
05 = 5 mm
10 = 10 mm
12,7 = 12.7 mm
16 = 16 mm
20 = 20 mm
25 = 25 mm

Series number _____

Project No. assigned by Diplomatic

Motor flange:
S = stepper
B = brushless
A = AC motor
D = DC motor
V = stepper with feedback
G = gearbox

Motor position:
0 = 12 o'clock
3 = 3 o'clock
6 = 6 o'clock
9 = 9 o'clock

Motor mounting type (NOTE):
(omit if not required)
L = in line
P = parallel (ratio 1 ÷ 1) (standard)
Q = parallel (ratio 2 ÷ 1)
X = parallel (custom ratio)

Limit switch:
N = none
A = single
D = double
T = triple
Q = quadruple

Lubrication:
N = none
F0 = centred 12 o'clock
F3 = centred 3 o'clock
F6 = centred 6 o'clock
F9 = centred 9 o'clock

Protection class:
N = IP44
S = IP65

Rotation stopper
N = none
P = present

NOTE: The size of the belt transmission box may change for types Q and X; contact the technical department to verify sizing.

2 - COMMON TECHNICAL CHARACTERISTICS

ACCURACY		mm	± 0.035
ENVIRONMENT	Ambient temperature range	°C	-20 / +100 (cylinder without motor)
	Protection class		IP44 or IP65
	Humidity	%	0 ÷ 90
MECHANICAL	Reference standard		ISO 15552
	Duty cycle	%	100
	Internal antirotation		available on all sizes
	Rod end		male or female
	Rod material		chromium-plated (standard) stainless steel upon request
	Mounting		on front cap or with accessories
	End stroke sensor		available on all sizes

3 - FEATURES OF USE

3.1 - Field of application

- In normal motion systems with ball screws in automation field; to replace normal cylinders when speed and controlled ramps are required, even under load.
- In any application where motion with considerable traction / thrust forces is required, instead of using hydraulic cylinders.
- In any system where absence of pollution and / or extreme silence is required.

3.2 - Applications

ISO 15552 ECS3 Electric Cylinders are the right solution for all those applications that require accurate and controlled positioning. They offer the opportunity to use pre-set solutions to solve the design and commissioning of automation systems quickly and simply.

The installation simplicity and the different construction types make the ECS3 Cylinder a reference point in this kind of product.

The wide possibility of choice among different types allows the use of the ECS3 even in demanding and critical applications, as they offer force capabilities and dynamic load ratings decisively heavier than standard market proposals.

The possibility to use most of standard pneumatic ISO 15552 accessories for the same size is an additional practical and cost advantage in mounting the cylinders.



4 - ECS3 - 32

4.1 - Technical Characteristics

MECHANICAL	Rod diameter	mm	20	
	Rod end		M10x1.25	
BALL SCREW	Nominal diameter	mm	14	12.7
	Lead	mm	4	12.7
	Dynamic load	N	6000	8000
FORCE	Max force - in line	N	2100	2100
	Max torque - in line	Nm	1.6	5.0
	Max force - parallel	N	2100	2100
	Max torque - parallel	Nm	1.8	5.5
	Dynamic axial force at 2500 km lifetime	N	702	1375
SPEED	Max speed	rpm	5714	6299
		mm/s	381	1333
ACCELERATION	Max acceleration	m/s ²	2.5	8.1
EFFICIENCY	In line	%	84	88
	Parallel	%	76	80

4.2 - Service Life

The service life depends on average dynamic axial load.

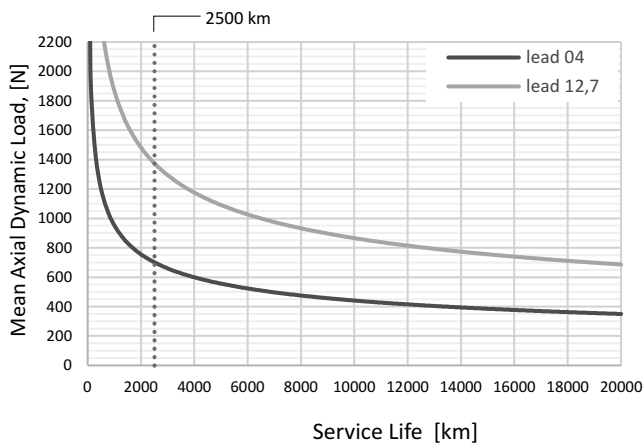

NOTES

- Service life is a statistical value and refers to 90%reliability.
- Correct working conditions: i.e. no lateral-load, no over-load, right lubrication, no over-temperature, no short-stroke application.
- The permissible axial force is calculated considering a pushing condition with free rod end and fixed barrel constraint. Contact us for different loading applications and for any questions

4.3 - Permissible Speed

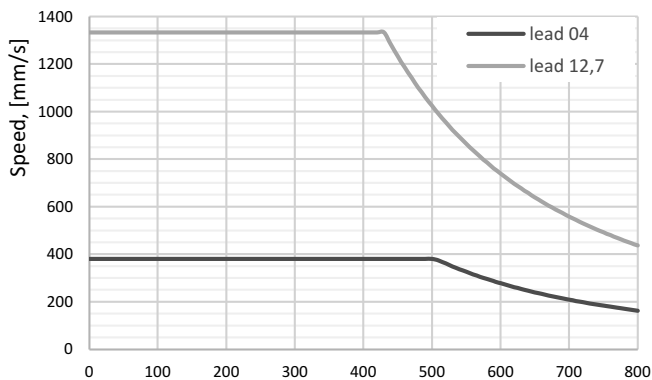

4.4 - Permissible Axial Force

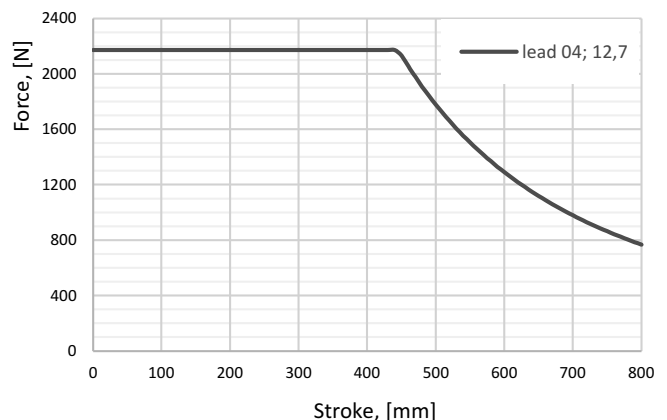

4.5 - ECS3-32 Overall Mounting Dimensions

dimensions in mm

In-line motor mounting

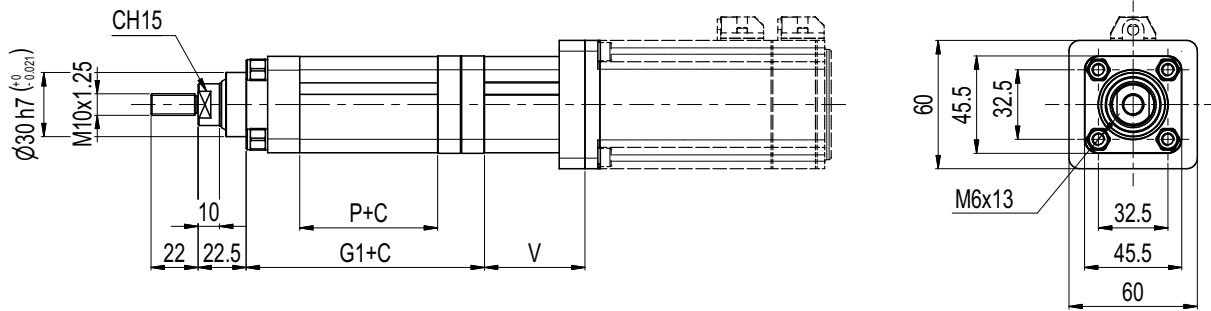

Parallel motor mounting

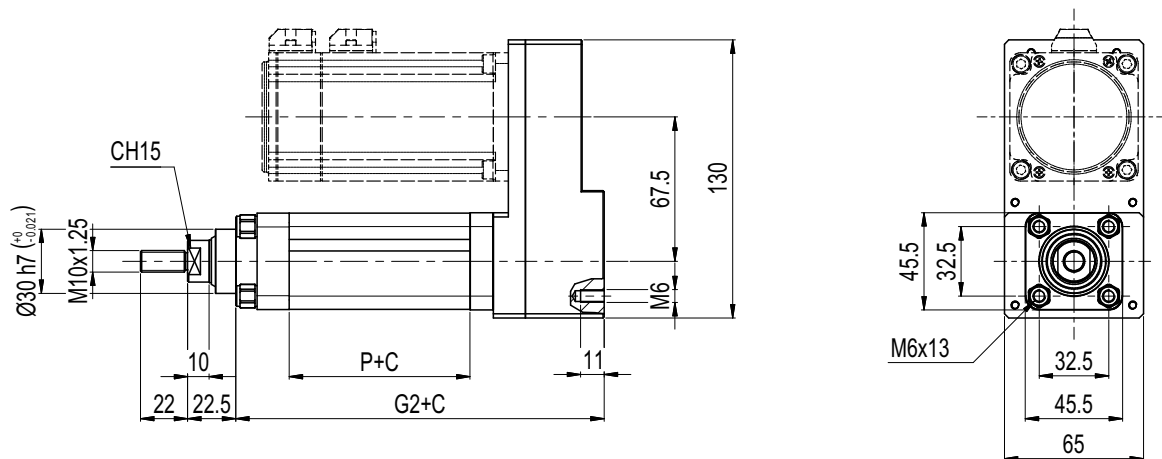

Ball Screw	P	G1	G2
12.7x12.7	84.5	131.4	172.25
14x4	64.5	111.4	152.25

C = Stroke value
V = Depending on motor dimensions



5 - ECS3-40

5.1 - Technical Characteristics

MECHANICAL	Rod diameter	mm	25		
	Rod end		M12x1.25		
BALL SCREW	Nominal diameter	mm	16	16	16
	Lead	mm	5	10	16
	Dynamic load	N	10104	6112	9150
FORCE	Max force - in line	N	3400	3400	3080
	Max torque - in line	Nm	3.2	6.3	8.9
	Max force - parallel	N	3400	3400	3400
	Max torque - parallel	Nm	3.6	7.0	11.0
	Dynamic axial force at 2500 km lifetime	N	1273	970	1699
SPEED	Max speed	rpm	5000	5000	5000
		mm/s	417	833	1333
ACCELERATION	Max acceleration	m/s ²	3.2	6.4	10.2
EFFICIENCY	In line	%	85	87	88
	Parallel	%	76	79	80

5.2 - Service Life

The service life depends on average dynamic axial load.

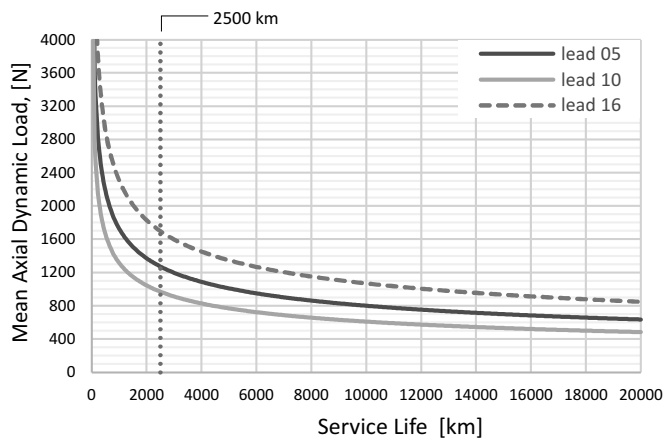

NOTES

- Service life is a statistical value and refers to 90%reliability.
- Correct working conditions: i.e. no lateral-load, no over-load, right lubrication, no over-temperature, no short-stroke application.
- The permissible axial force is calculated considering a pushing condition with free rod end and fixed barrel constraint. Contact us for different loading applications and for any questions

5.3 - Permissible Speed

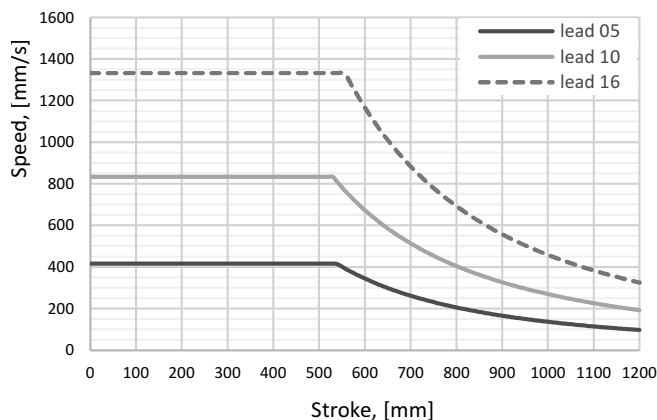

5.4 - Permissible Axial Force

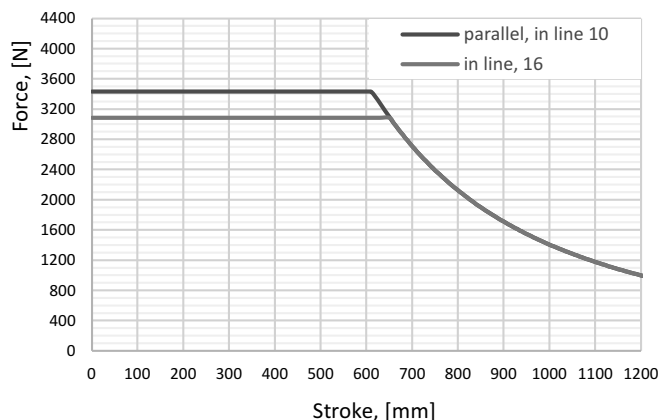

5.5 - ECS3-40 Overall Mounting Dimensions

dimensions in mm

In-line motor mounting

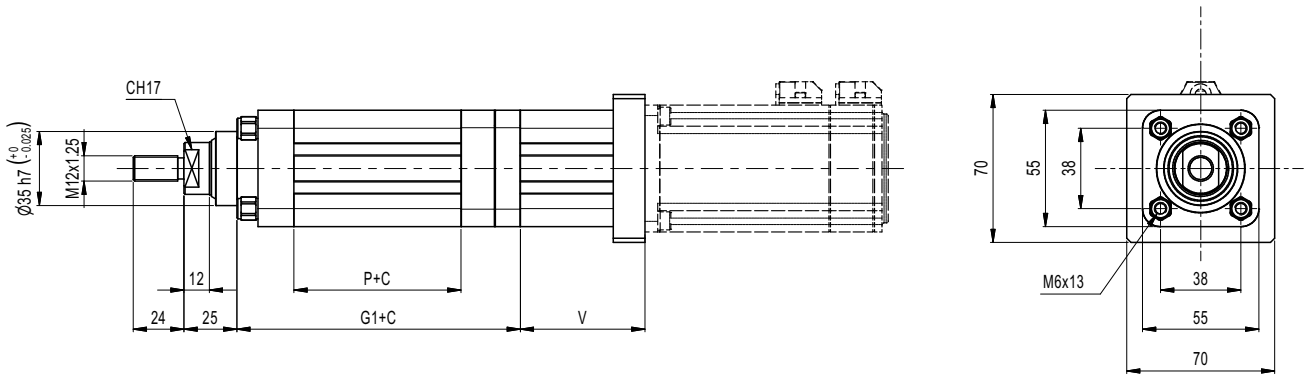

Parallel motor mounting

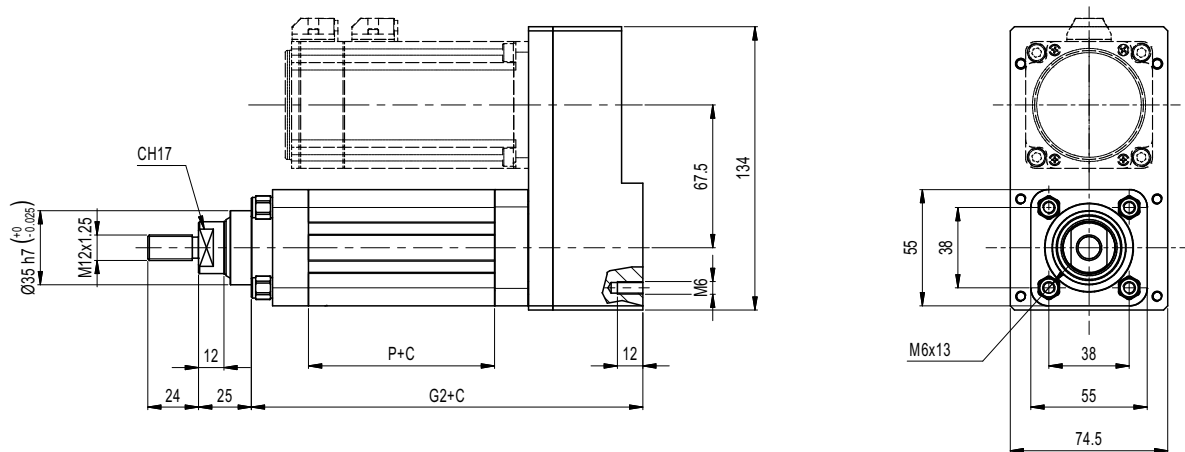

Ball Screw	P	G1	G2
16x5	88	143.1	185.1
16x10	96	151.1	193.1
16x16	79	134.1	176.1

C = Stroke value
V = Depending on motor dimensions

6 - ECS3- 50

6.1 - Technical Characteristics

MECHANICAL	Rod diameter	mm	30		
	Rod end		M16x1.5		
BALL SCREW	Nominal diameter	mm	20	20	20
	Lead	mm	5	10	20
	Dynamic load	N	11154	11272	10000
FORCE	Max force - in line	N	6400	4850	2470
	Max torque - in line	Nm	6.1	8.9	8.9
	Max force - parallel	N	6400	6400	5830
	Max torque - parallel	Nm	6.8	13.1	23.3
	Dynamic axial force at 2500 km lifetime	N	1405	1789	2000
SPEED	Max speed	rpm	4000	4000	4000
		mm/s	333	667	1333
ACCELERATION	Max acceleration	m/s ²	3.2	6.4	12.7
EFFICIENCY	In line	%	84	87	88
	Parallel	%	75	78	80

6.2 - Service Life

The service life depends on average dynamic axial load.

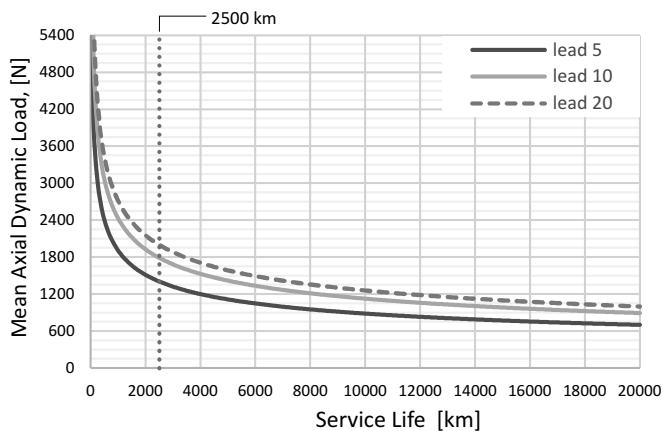

NOTES

- Service life is a statistical value and refers to 90%reliability.
- Correct working conditions: i.e. no lateral-load, no over-load, right lubrication, no over-temperature, no short-stroke application.
- The permissible axial force is calculated considering a pushing condition with free rod end and fixed barrel constraint. Contact us for different loading applications and for any questions

6.3 - Permissible Speed

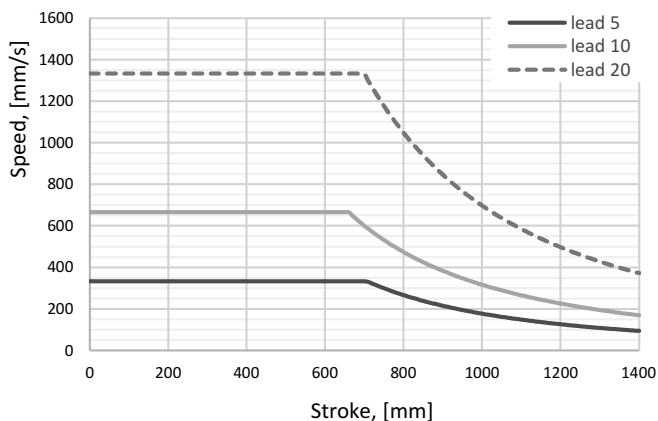

6.4 - Permissible Axial Force

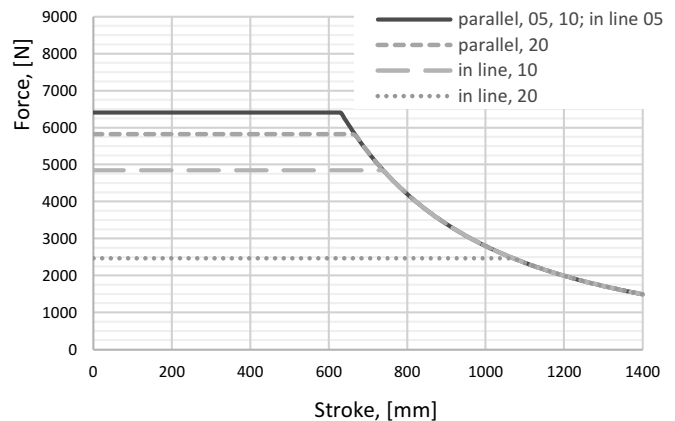

6.5 - ECS3-50 Overall Mounting Dimensions

dimensions in mm

In-line motor mounting

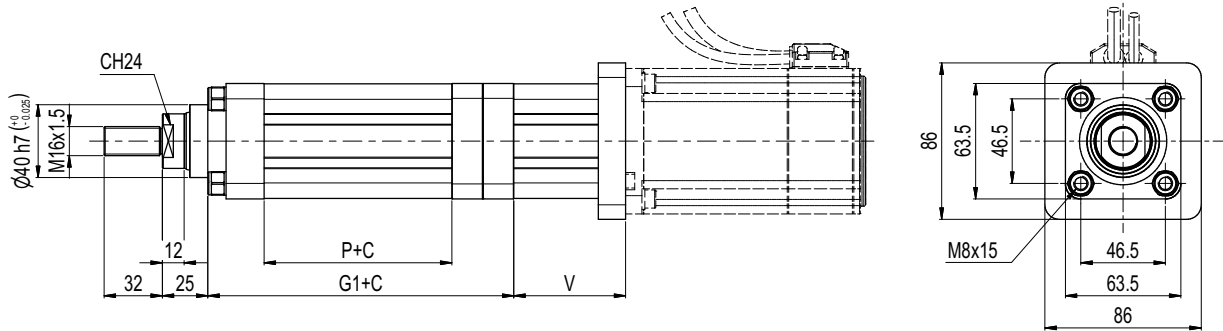

Parallel motor mounting

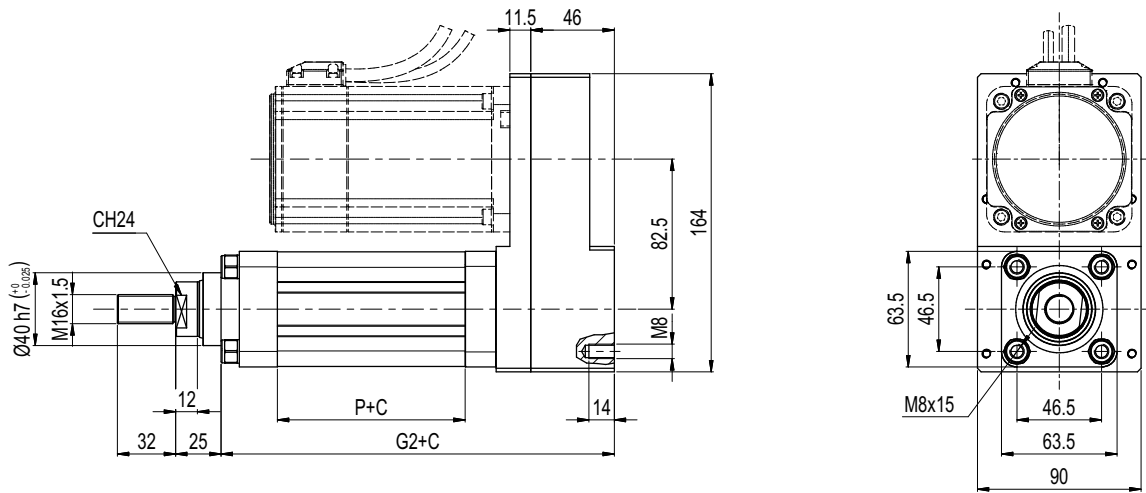

Ball Screw	P	G1	G2
20x5	103.2	168.3	216.3
20x10	112.2	177.3	225.3
20x20	96.2	161.3	209.3

C = Stroke value
V = Depending on motor dimensions



7 - ECS3-63

7.1 - Technical Characteristics

MECHANICAL	Rod diameter	mm	35		
	Rod end		M16x1.5		
BALL SCREW	Nominal diameter	mm	25	25	25
	Lead	mm	5	10	25
	Dynamic load	N	16383	15990	16873
FORCE	Max force - in line	N	11100	11100	5890
	Max torque - in line	Nm	10.8	20.6	26.5
	Max force - parallel	N	11100	11100	5890
	Max torque - parallel	Nm	11.9	22.9	29.5
	Dynamic axial force at 2500 km lifetime	N	2064	2538	3635
SPEED	Max speed	rpm	3200	3200	3200
		mm/s	267	533	1333
ACCELERATION	Max acceleration	m/s ²	3.2	6.4	15.9
EFFICIENCY	In line	%	82	86	88
	Parallel	%	74	77	80

7.2 - Service Life

The service life depends on average dynamic axial load.

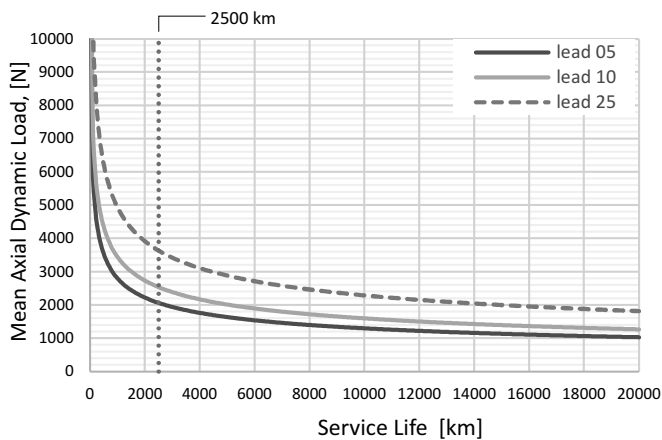

NOTES

- Service life is a statistical value and refers to 90%reliability.
- Correct working conditions: i.e. no lateral-load, no over-load, right lubrication, no over-temperature, no short-stroke application.
- The permissible axial force is calculated considering a pushing condition with free rod end and fixed barrel constraint. Contact us for different loading applications and for any questions

7.3 - Permissible Speed

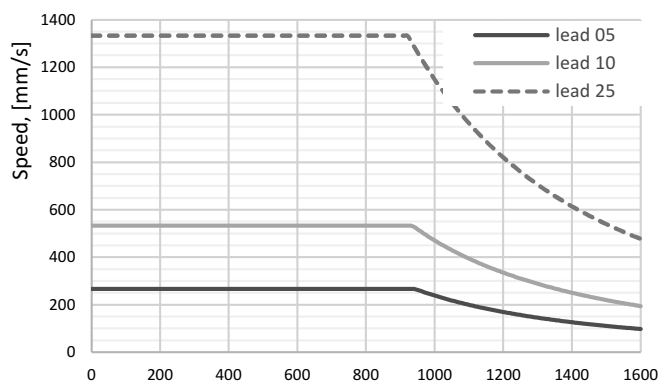

7.4 - Permissible Axial Force

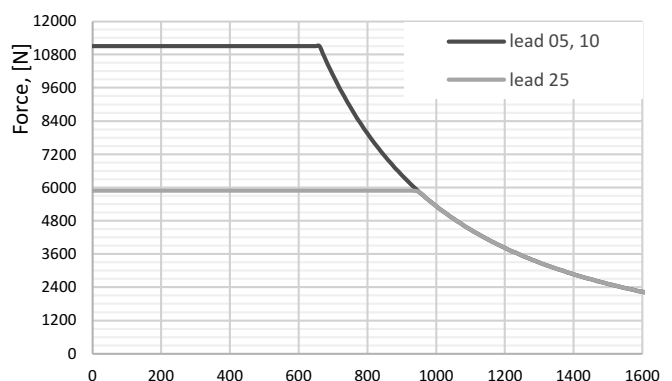

7.5 - ECS3-63 Overall Mounting Dimensions

dimensions in mm

In-line motor mounting

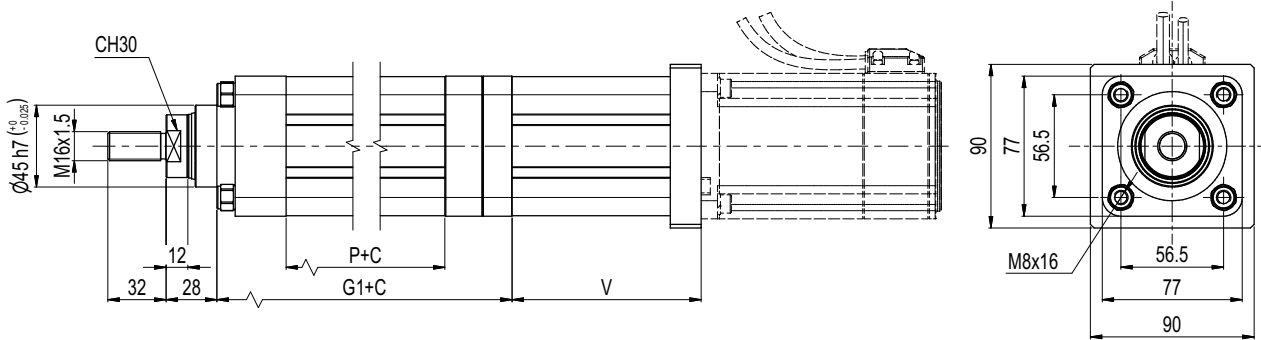

Parallel motor mounting

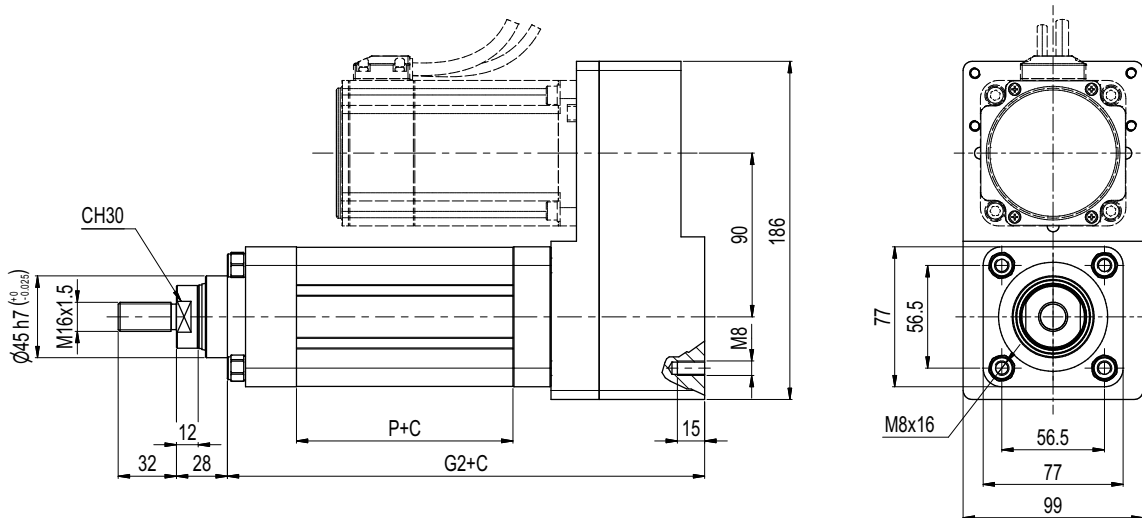

Ball Screw	P	G1	G2
25x05	119.1	194.1	262.6
25x10	119.1	194.1	262.6
25x25	119.1	194.1	262.6

C = Stroke value

V = Depending on motor dimensions



8 - ECS3-80

8.1 - Technical Characteristics

MECHANICAL	Rod diameter	mm	45		
	Rod end		M20x1.5		
BALL SCREW	Nominal diameter	mm	32	32	32
	Lead	mm	5	10	20
	Dynamic load	N	15333	28439	20895
FORCE	Max force - in line	N	13100	20900	12300
	Max torque - in line	Nm	13.0	39.3	45.0
	Max force - parallel	N	13100	20900	15990
	Max torque - parallel	Nm	14.5	43.6	64.7
	Dynamic axial force at 2500 km lifetime	N	1932	4514	4179
SPEED	Max speed	rpm	2500	2500	2500
		mm/s	208	417	833
ACCELERATION	Max acceleration	m/s ²	3.2	6.4	12.7
EFFICIENCY	In line	%	80	85	85
	Parallel	%	72	76	76

8.2 - Service Life

The service life depends on average dynamic axial load.

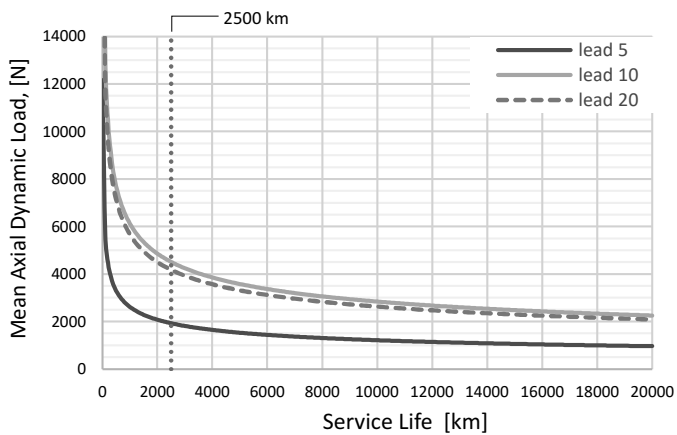

NOTES

- Service life is a statistical value and refers to 90%reliability.
- Correct working conditions: i.e. no lateral-load, no over-load, right lubrication, no over-temperature, no short-stroke application.
- The permissible axial force is calculated considering a pushing condition with free rod end and fixed barrel constraint. Contact us for different loading applications and for any questions

8.3 - Permissible Speed

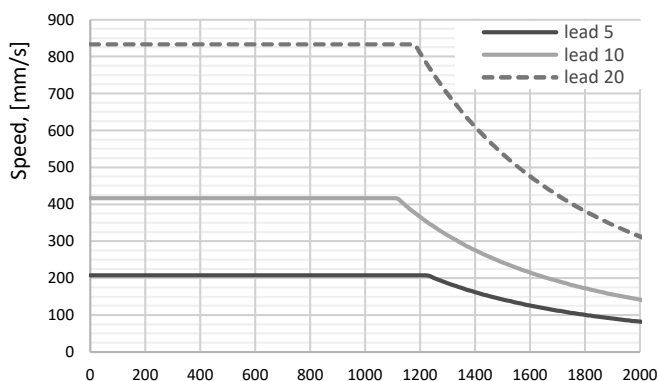

8.4 - Permissible Axial Force

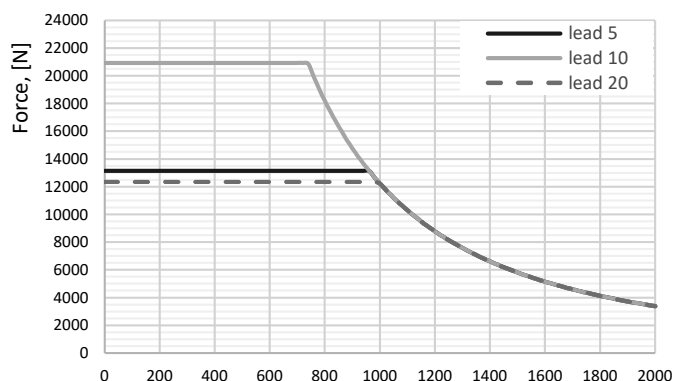

8.5 - ECS3-80 Overall Mounting Dimensions

dimensions in mm

In-line motor mounting

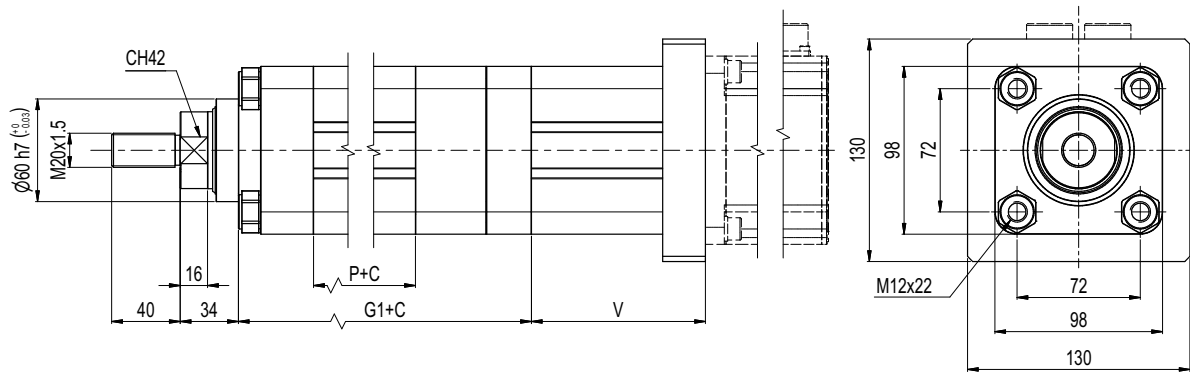

Parallel motor mounting

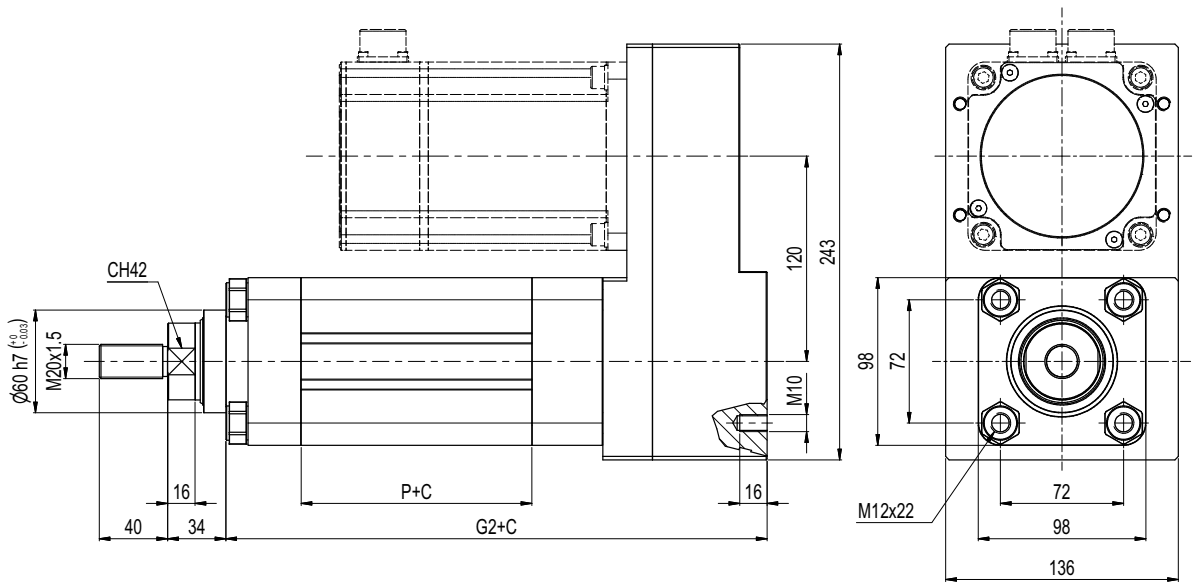

Ball Screw	P	G1	G2
32x05	110.8	221.6	291.3
32x10	140.8	252.6	322.3
32x20	136.8	248.6	318.3

C = Stroke value
V = Depending on motor dimensions



9 - ECS3-100

9.1 - Technical Characteristics

MECHANICAL	Rod diameter	mm	70
	Rod end		M42x2
BALL SCREW	Nominal diameter	mm	50
	Lead	mm	20
	Dynamic load	N	98718
FORCE	Max force - in line	N	53500
	Max torque - in line	Nm	198.3
	Max force - parallel	N	53500
	Max torque - parallel	Nm	210.9
	Dynamic axial force at 2500 km lifetime	N	19744
SPEED	Max speed	rpm	1600
		mm/s	533
ACCELERATION	Max acceleration	m/s ²	12.7
EFFICIENCY	In line	%	86
	Parallel	%	81

9.2 - Service Life

The service life depends on average dynamic axial load.

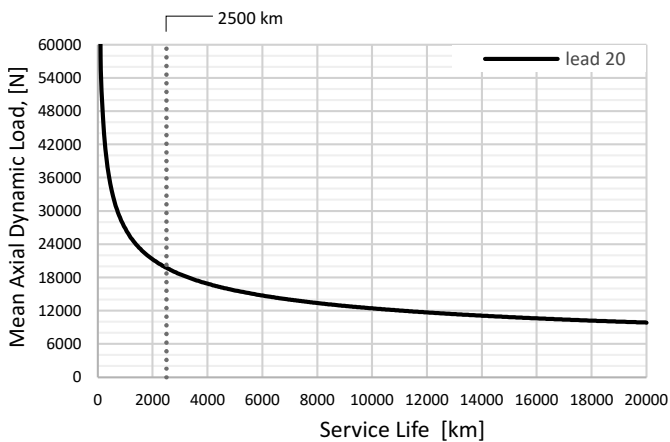

NOTES

- Service life is a statistical value and refers to 90%reliability.
- Correct working conditions: i.e. no lateral-load, no over-load, right lubrication, no over-temperature, no short-stroke application.
- The permissible axial force is calculated considering a pushing condition with free rod end and fixed barrel constraint. Contact us for different loading applications and for any questions

9.3 - Permissible Speed

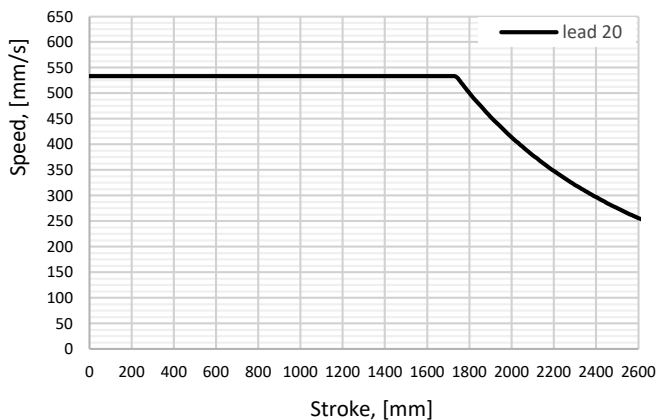

9.4 - Permissible Axial Force

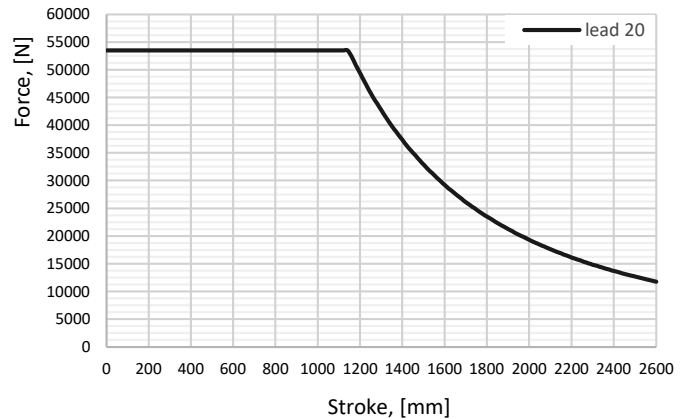

9.5 - ECS3-100 Overall Mounting Dimensions

dimensions in mm

In-line motor mounting

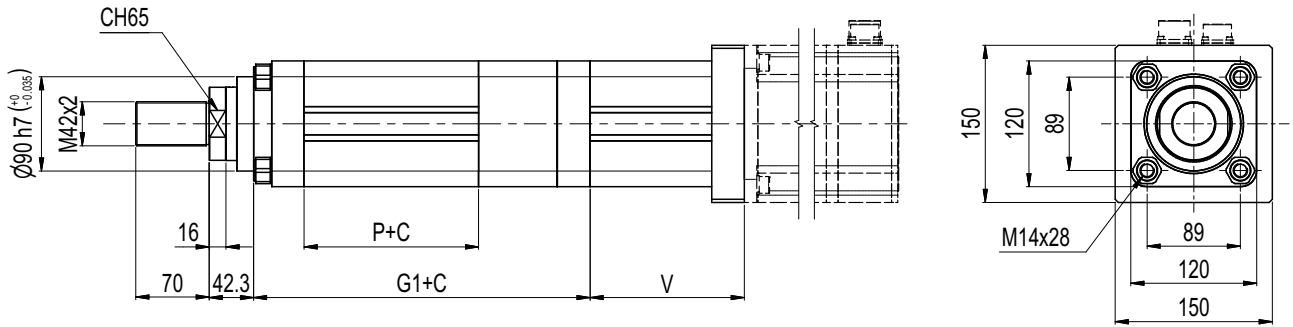

Parallel motor mounting

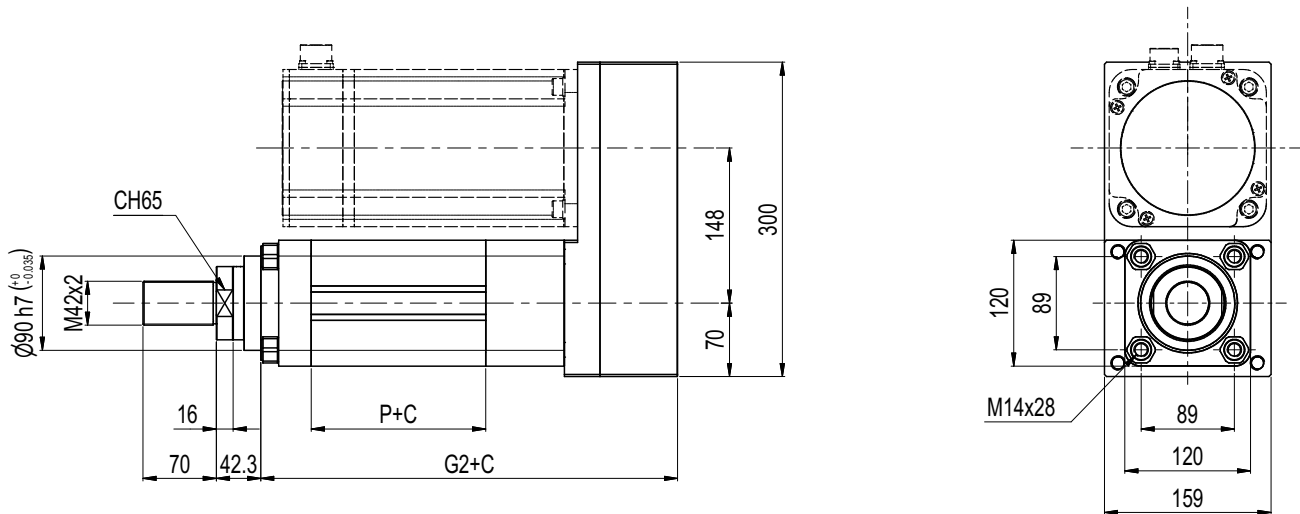

Ball Screw	P	G1	G2
50x20	219.5	374.1	450.8

C = Stroke value
V = Depending on motor dimensions



10 - ECS3-125

10.1 - Technical Characteristics

MECHANICAL	Rod diameter	mm	85	
	Rod end		M48x2	
BALL SCREW	Nominal diameter	mm	63	63
	Lead	mm	10	20
	Dynamic load	N	80148	248193
FORCE	Max force - in line	N	103800	123400
	Max torque - in line	Nm	205.4	462.7
	Max force - parallel	N	103800	123400
	Max torque - parallel	Nm	218.5	492.2
	Dynamic axial force at 2500 km lifetime	N	12723	49639
SPEED	Max speed	rpm	1270	1270
		mm/s	212	423
ACCELERATION	Max acceleration	m/s ²	6.4	12.7
EFFICIENCY	In line	%	80	85
	Parallel	%	76	80

10.2 - Service Life

The service life depends on average dynamic axial load.

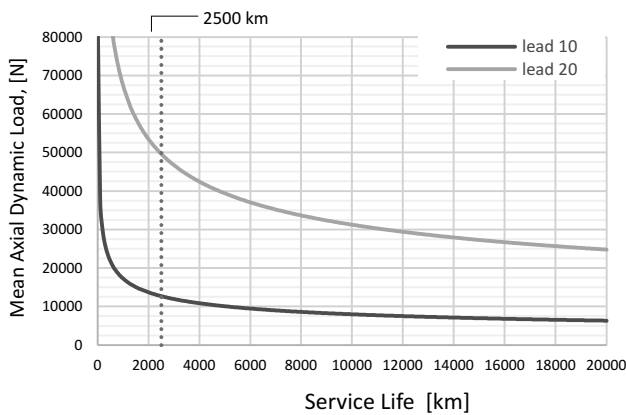

NOTES

- Service life is a statistical value and refers to 90%reliability.
- Correct working conditions: i.e. no lateral-load, no over-load, right lubrication, no over-temperature, no short-stroke application.
- The permissible axial force is calculated considering a pushing condition with free rod end and fixed barrel constraint. Contact us for different loading applications and for any questions

10.3 - Permissible Speed

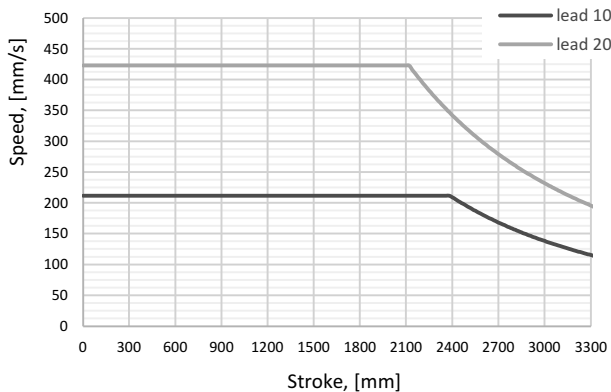

10.4 - Permissible Axial Force

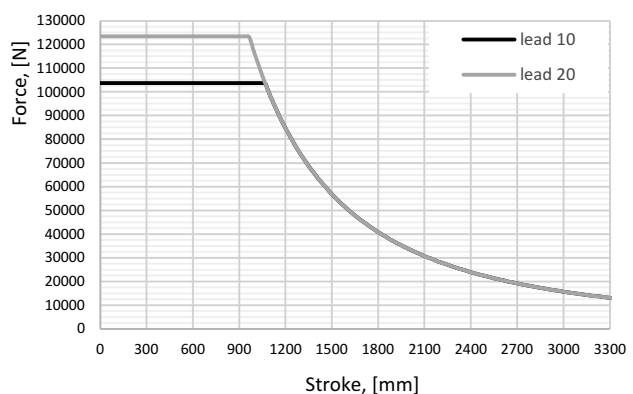

10.5 - ECS3-125 Overall Mounting Dimensions

dimensions in mm

In-line motor mounting

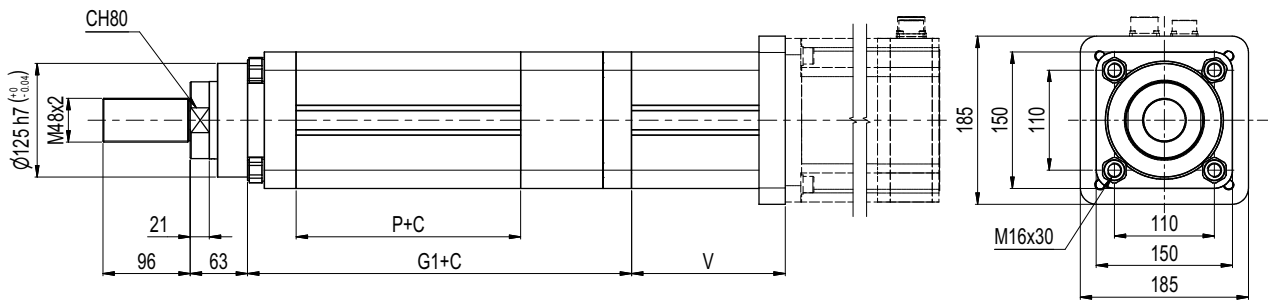

Parallel motor mounting

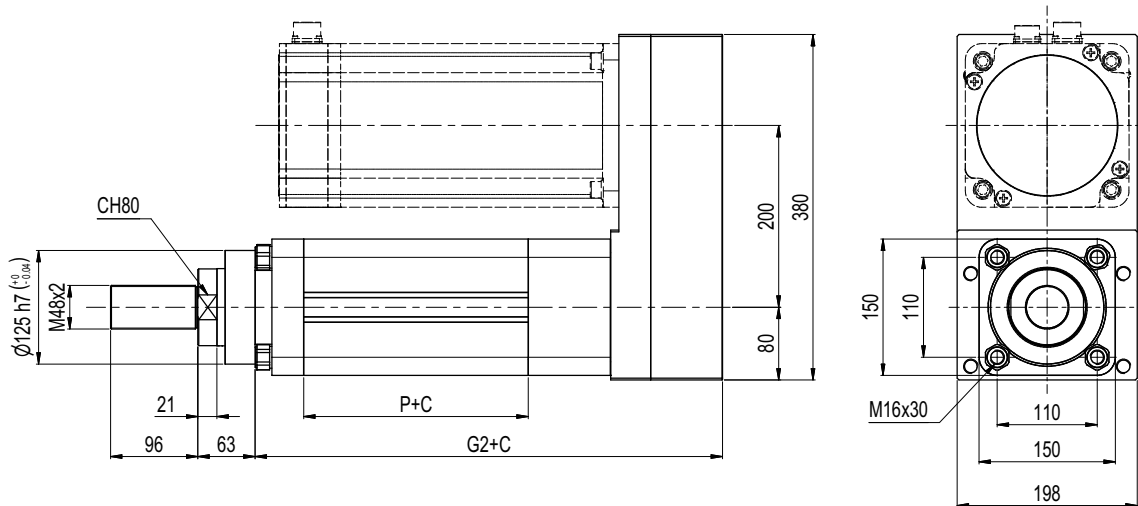

Ball Screw	P	G1	G2
63x10	177.2	352.7	444.4
63x20	291	466.5	558.2

C = Stroke value
V = Depending on motor dimensions

11 - MOUNTING TYPE A AND B

A FRONT FLANGE (MF1)

B REAR FLANGE (MF2)

dimensions in mm

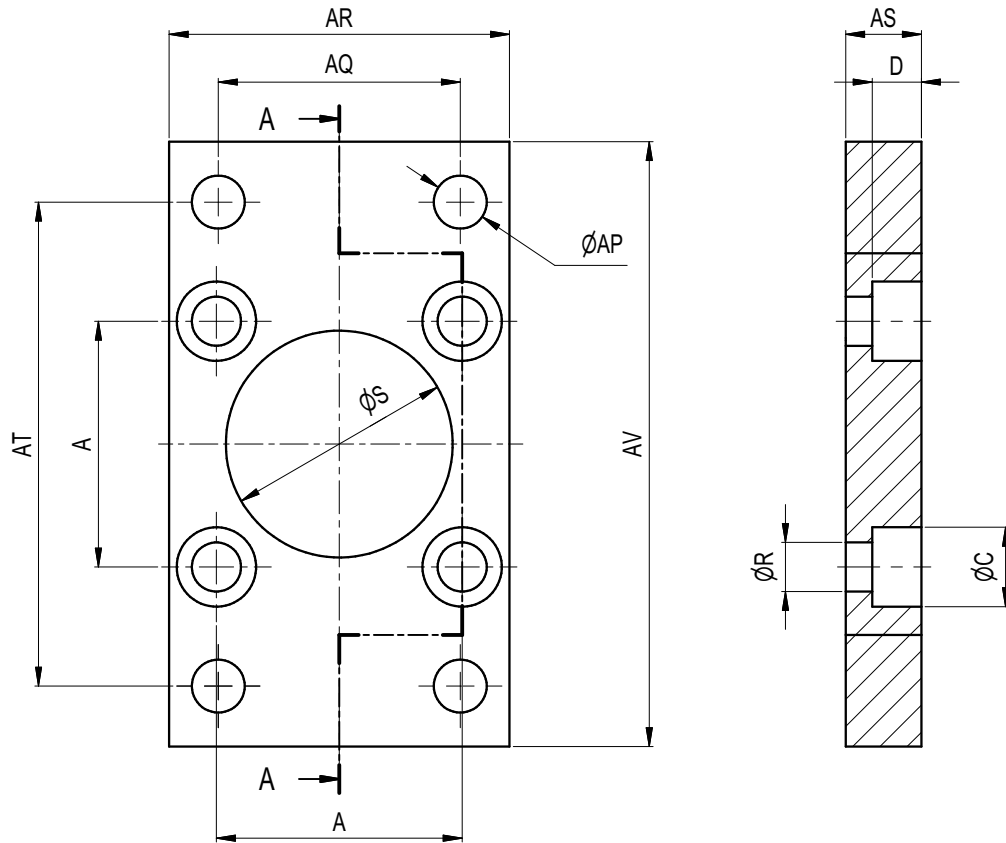

NOTE: Can bear same permissible forces allowed on the cylinders

Size	S H11	A ± 0.2	AP H13	R	AS ± 0.2	AR	AQ JS14	AT JS14	AV	C	D
FFP-32	30	32.5	7	6.5	10	45	32	64	80	10.5	6.5
FFP-40	35	38	9	6.5	10	52	36	72	90	10.5	6.5
FFP-50	40	46.5	9	8.5	12	65	45	90	110	13.5	8.5
FFP-63	45	56.5	9	8.5	12	75	50	100	120	13.5	8.5
FFP-80	60	72	12	12.5	18	95	63	126	150	19	13
FFP-100	90	89	14.5	14.5	20	115	75	150	170	22	15
FFP-125	125	110	16.5	16.5	25	140	90	180	205	25	18

12 - MOUNTING TYPE C

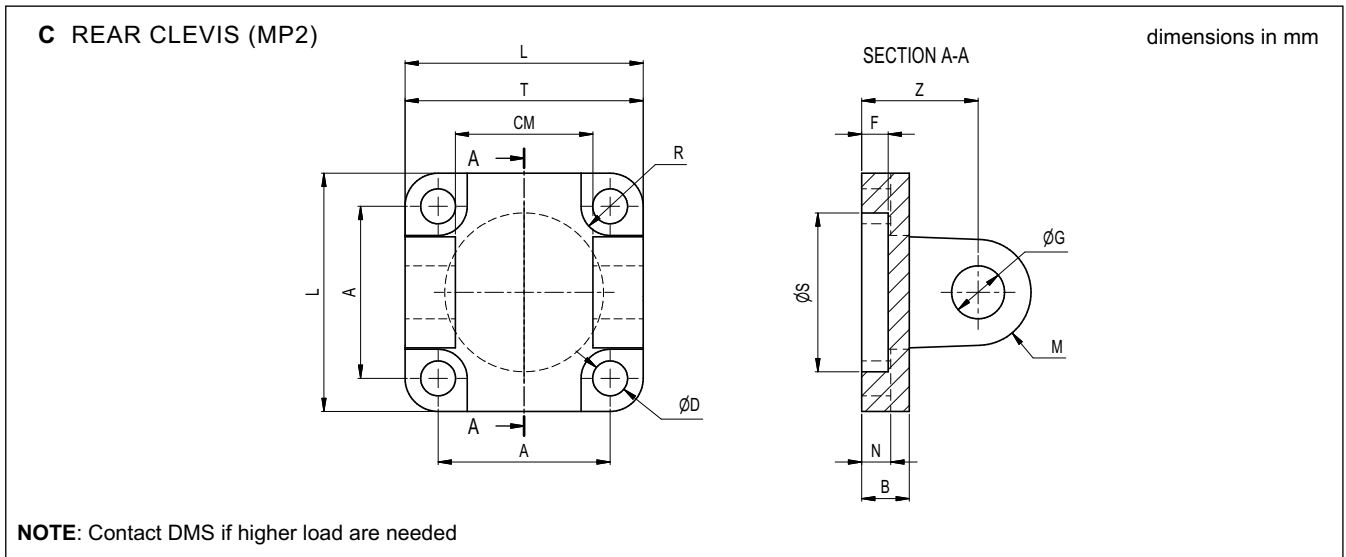

NOTE: Contact DMS if higher load are needed

Size	G H9	A ± 0.2	L	D H13	R H13	N ± 0.5	B	S H11	F	Z ± 0.2	M	CM H14	T h14	Max Load
RPC-32	10	32.5	45	6.6	11	5.5	9	30	5	22	10	26	45	1760
RPC-40	12	38	52	6.6	11	5.5	9	35	5	25	12	28	52	3230
RPC-50	12	46.5	65	9	15	6.5	11	40	5	27	12	32	60	5150
RPC-63	16	56.5	75	9	15	6.5	11	45	5	32	16	40	70	7010
RPC-80	16	72	95	11	18	10	14	45	5	36	16	50	90	12060
RPC-100	25	110	140	14	20	10	20	60	7	50	25	70	130	20220
RPC-125	30	140	180	18	26	10	20	65	7	55	25	90	170	32730

12.1 - Rear Square Bracket

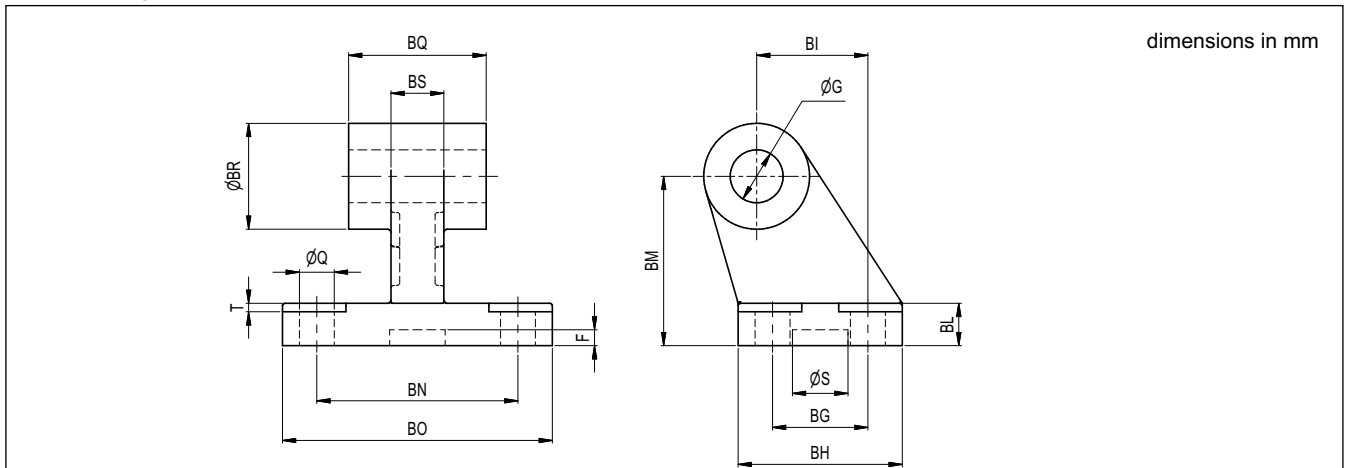

NOTE: Contact DMS if higher load are needed

Type	Size	G H9	Q H13	M H13	BG JS14	BH max	BI JS14	BL	BM JS15	BN JS14	BO max	BS max	BR max	T max	S $+0.5$ 0	F $+0.5$ 0	BQ -0.2 -0.6	Max Load
SBP-32	32	10	6.6	11	18	31	21	8	32	38	51	10	20	1.6	10.5	3	26	1440
SBP-40	40	12	6.6	11	22	35	24	10	36	41	54	10	22	8.5	20	3	28	1960
SBP-50	50	12	9	15	30	45	33	12	45	50	65	16	26	1.6	10.5	3	32	5520
SBP-63	63	16	16	15	35	50	37	12	50	52	67	14	30	10.5	20	3	40	5110
SBP-80	80	16	11	18	40	60	47	14	63	66	86	20	30	2.5	10.5	3	50	11310
SBP-100	100	25	14	20	60	90	70	20	90	94	124	30	45	3.2	10.5	3	70 (*)	18180
SBP-125	125	30	14	20	88	126	97	25	115	118	156	36	63	4	-	-	90 (*)	30920

(*) Tolerance values -0.5
 -1.2

12.2 - Pin for Rear Clevis

	Type	Size	G e8	BT +0.3 0	CG	CH H13	BU
	PNP-32	32	10	46	9.6	1.1	53
	PNP-40	40	12	53	11.5	1.1	60
	PNP-50	50	12	61	11.5	1.1	68
	PNP-63	63	16	71	15.2	1.1	78
	PNP-80	80	16	91	15.2	1.1	98
	PNP-100	100	25	132	23.9	1.3	139
	PNP-125	125	30	171.5	28.6	1.6	178

NOTE: Can bear same permissible forces allowed on related accessories

13 - MOUNTING TYPE D

D REAR EYE (MP4) dimensions in mm

NOTE: Contact DMS if higher load are needed

Type	G H9	A ±0.2	L	D H13	R H13	N ±0.5	H	S H11	F	C ±0.2	T max	B -0.2 -0.6	Max Load
REP-32	10	32.5	45	6.6	11	5.5	9	30	5	22	10	26	2410
REP-40	12	38	52	6.6	11	5.5	9	35	5	25	12	28	3770
REP-50	12	46.5	65	9	15	6.5	11	40	5	27	12	32	5890
REP-63	16	56.5	75	9	15	6.5	11	45	5	32	16	40	9550
REP-80	16	72	95	11	18	10	14	45	5	36	16	50	15080
REP-100	25	110	140	14	20	10	20	60	7	50	25	70	23560
REP-125	30	140	180	18	26	10	26	65	7	55	25	90	36820

14 - MOUNTING TYPE G

G FEET (MS1) dimensions in mm

NOTE: Do not use to bear load. If force of the application is applied on this accessory, please contact DMS for technical analysis

Type	Size	C ± 0.2	B JS14	D 0 -0.2	E	F +2 0	G H14	H ± 0.2	I ± 0.2	S ± 0.5	T JS15	R H15	U	Z H14
FTP-32	32	32.5	32	45	35	30	7	15.75	24	4	32	15	11	7
FTP-40	40	38	36	52	36	30	7	17	28	4	36	17.5	15	9
FTP-50	50	46.5	45	65	47	36	9	21.75	32	5	45	20	16	9
FTP-63	63	56.5	50	75	45	35	9	21.75	32	5	50	22.5	18	9
FTP-80	80	72	63	95	55	47	11	27	41	6	63	30	17	12
FTP-100	100	89	75	115	57	53	11	26.5	41	6	71	45	24	14.5
FTP-125	125	110	90	140	70	70	14	35	45	8	90	62.5	-	16.5

15 - MOUNTING TYPE L

L INTERMEDIATE TRUNNIONS (MT4) dimensions in mm

NOTE: Do not use to bear load. If force of the application is applied on this accessory, please contact DMS for technical analysis

Type	Size	A	B	C	D	H
TRP-32	32	70	12	50	12	18
TRP-40	40	78	16	62	16	20
TRP-50	50	91	16	74	16	20
TRP-63	63	94	20	88	20	25
TRP-80	80	130	20	109	20	25
TRP-100	100	145	25	130	25	30
TRP-125	125	154	25	155	25	32

15.1 - Lateral Bracket

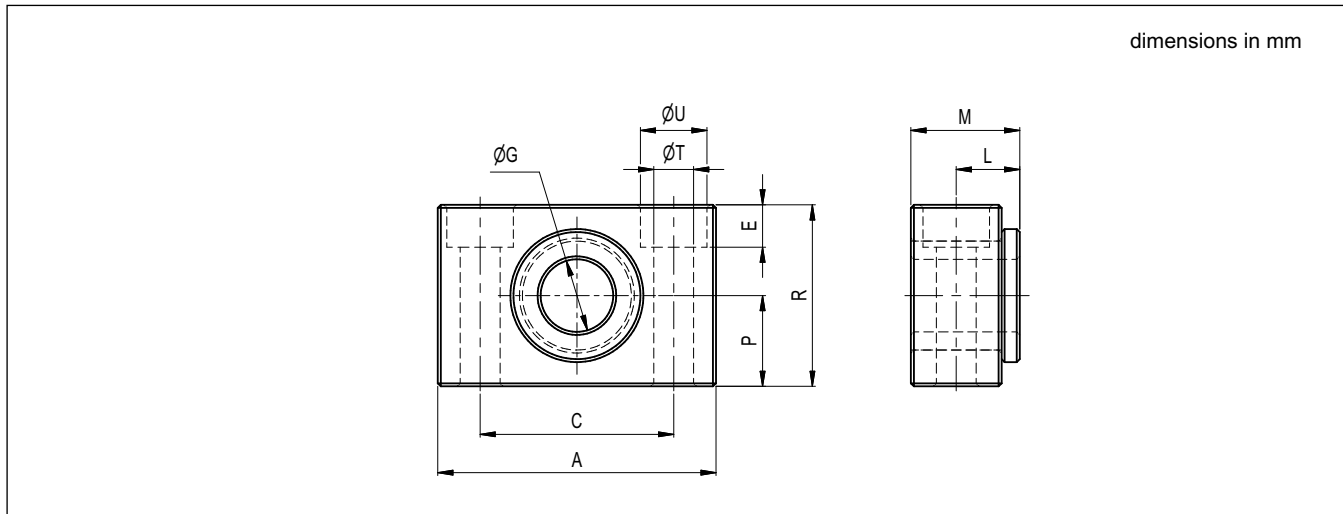

NOTE: Do not use to bear load. If force of the application is applied on this accessory, please contact DMS for technical analysis

Type	Size	G F7	A	M	R	P ±0.1	C ±0.2	L	U H13	T H13	E ±0.5
BRP-12	32	12	46	18	30	15	32	10.5	11	6.6	7
BRP-16	40	16	55	21	36	18	36	12	15	9	9
	50	16	55	21	36	18	36	12	15	9	9
BRP-20	63	20	65	23	40	20	42	13	18	11	11
	80	20	65	23	40	20	42	13	18	11	11
BRP-25	100	25	75	28.5	50	25	50	16	20	14	13
	125	25	75	28.5	50	25	50	16	20	14	13

16 - OVERALL MOUNTING DIMENSIONS FOR ROD END

16.1 - Female Thread

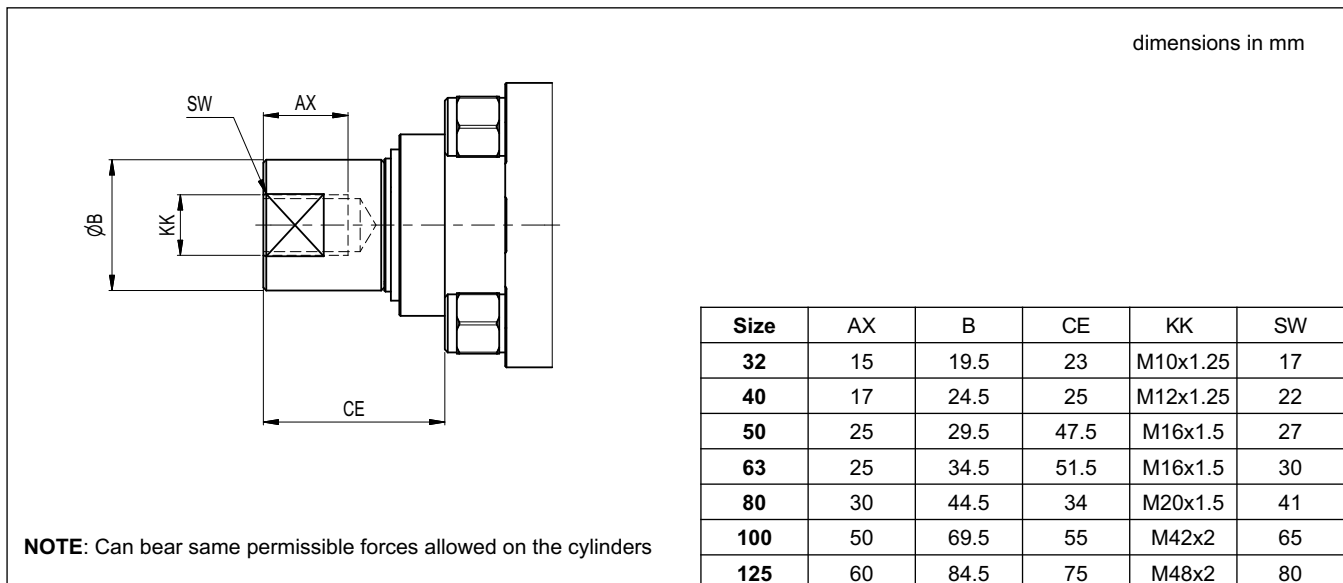

16.2 - Clevis Cap (ISO 8140)

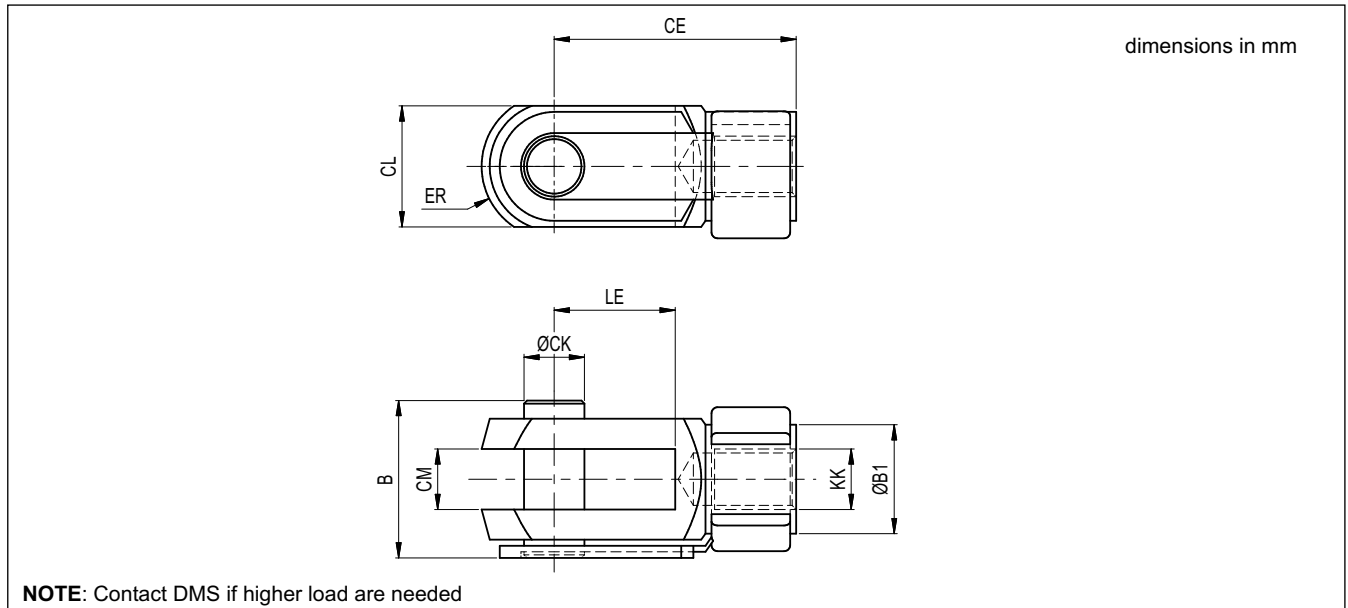

NOTE: Contact DMS if higher load are needed

Type	Size	KK	CK	LE	CM	CL	ER	CE	B	B1	Max Load
CLP-M10	32	M10x1.25	10	20	10	20	12	40	26	18	5000
CLP-M12	40	M12x1.25	12	24	12	24	14	48	32	20	7200
CLP-M16	50	M16x1.5	16	32	16	32	19	64	40	26	12800
CLP-M16	63	M16x1.5	16	32	16	32	19	64	40	26	12800
CLP-M20	80	M20x1.5	20	40	20	40	25	80	48	34	20000
CLP-M42	100	M42x2	40	84	40	85	64	168	104.3	70	88750
CLP-M48	125	M48x2	50	96	50	96	73	192	117.3	82	102500

16.3 - Spherical Cap (ISO 8139)

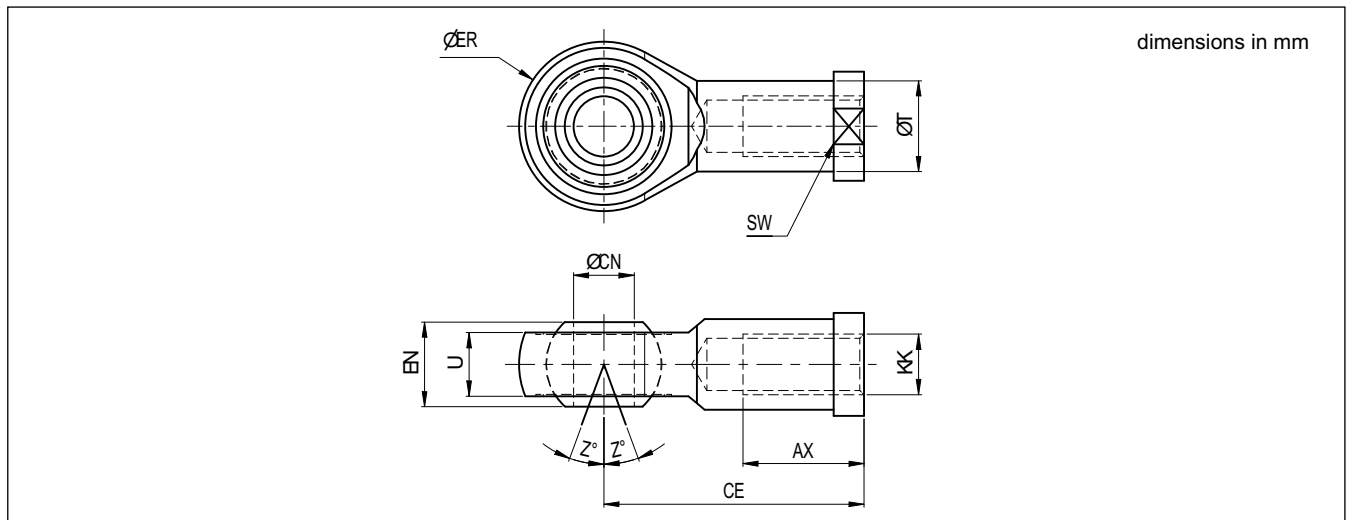

NOTE: Contact DMS if higher load are needed

Type	Size	KK	CN	U	EN	ER	AX	CE	T	Z	SW	Max Load
SPP-M10	32	M10x1.25	10	10.5	14	28	20	43	15	6.5	17	3500
SPP-M12	40	M12x1.25	12	12	16	32	22	50	17.5	6.5	19	4750
SPP-M16	50	M16x1.5	16	15	21	42	28	64	22	7.5	22	12000
SPP-M16	63	M16x1.5	16	15	21	42	28	64	22	7.5	22	12000
SPP-M20	80	M20x1.5	20	18	25	50	33	77	27.5	7	30	13000
SPP-M42	100	M42x2	40	33	49	91	60	142	53	8	55	65000
SPP-M48	125	M48x2	50	45	60	117	65	162	65	7	65	77000

16.4 - Self-Centering Coupler Cap

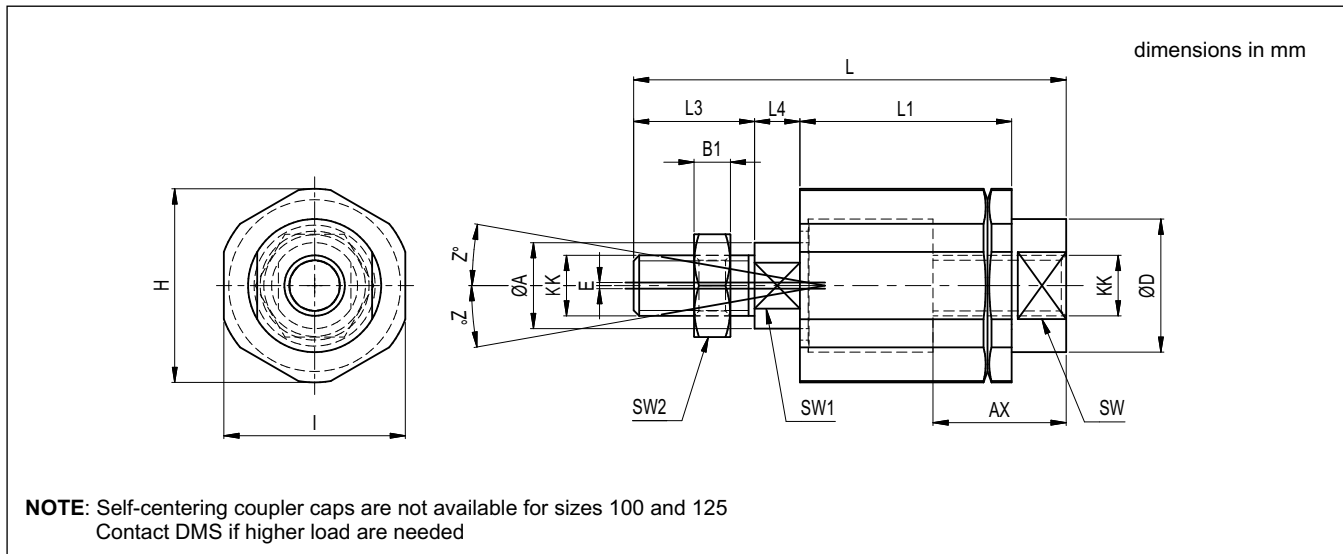

Type	Size	KK	L	L1	L3	L4	A	D	H	I	SW	SW1	SW2	B1	AX	Z	E	Max Load
COP-M10	32	M10x1.25	71.5	35	20	7.5	14	22	32	30	19	12	17	5	22	4	2	1250
COP-M12	40	M12x1.25	75.5	35	24	7.5	14	22	32	30	19	12	19	6	22	4	2	1250
COP-M16	50	M16x1.5	104	53	32	10	22	32	45	41	27	20	24	8	30	3	2	2500
	63	M16x1.5	104	53	32	10	22	32	45	41	27	20	24	8	30	3	2	2500
COP-M20	80	M20x1.5	119	53	40	10	22	32	45	41	27	20	30	10	37	3	2	2500